

АКУСТОЭЛЕКТРОННІ СЕНСОРИ

ACOUSTOELECTRONIC SENSORS

UDC 621.37/39:534

THE STATE AND PROSPECTS OF THE SENSOR ELECTRONICS BASED ON ACOUSTOELECTRONIC PHENOMENA

Ya. I. Lepikh

Odessa National I.I. Mechnikov University, 65026 Odessa, 2, str. Dvoryanskaya, Ukraine, ph/fax.
+38 (0482) -23-34-61, E-mail: ndl_lepikh@mail.ru

The summary

In this paper the opportunities acoustoelectronic phenomena use for new generation sensors creation which correspond to requirements of essential increase their metrological characteristics and intellectualization are considered.

The achieved results sensors constructed on a basis of acoustoelectronic effects having place at surface acoustic waves propagation researches and development are analyzed.

The results the new construction perspective principles researches of such sensors class are given. The constructive-technological decisions of some physical sensors and gas sensors are described. The possible development application fields are specified and the basic characteristics of some sensors are resulted.

Key words: acoustic phenomena, surface acoustic waves, sensor, film structures, adsorption. **Аннотация**

СОСТОЯНИЕ И ПЕРСПЕКТИВЫ СЕНСОРНОЙ ЭЛЕКТРОНИКИ НА ОСНОВЕ АКУСТОЭЛЕКТРОННЫХ ЯВЛЕНИЙ

Я. И. Лепих

В статье с позиции необходимости создания нового поколения сенсоров, отвечающих требованиям существенного повышения их метрологических характеристик и интеллектуализации, рассмотрены возможности использования для этой цели акустоэлектронных явлений.

Проанализированы достигнутые результаты исследований и разработок сенсоров, построенных на основе акустоэлектронных эффектов имеющих место при распространении поверхностных акустических волн.

Приведены результаты исследований новых перспективных принципов построения такого класса сенсоров. Описаны конструктивно-технологические решения некоторых

Ключевые слова: акустоэлектронные явления, поверхностные акустические волны, сенсор, пленочные структуры, адсорбция.

Анотація

СТАН І ПЕРСПЕКТИВИ СЕНСОРНОЇ ЕЛЕКТРОНІКИ НА ОСНОВІ АКУСТОЕЛЕКТРОННИХ ЯВИЩ

Я. І. Лепіх

У статті з позиції необхідності створення нового покоління сенсорів, що відповідають вимогам істотного підвищення їх метрологічних характеристик і інтелектуалізації, розглянуті можливості використання для цієї мети акустоелектронних явищ.

Проаналізовано досягнуті результати досліджень і розробок сенсорів, побудованих на основі акустоелектронних ефектів, що мають місце при поширенні поверхневих акустичних хвиль.

Приведено результати досліджень нових перспективних принципів побудови сенсорів такого класу. Описано конструктивно-технологічні рішення деяких сенсорів фізичних величин і сенсорів газу. Зазначено можливі області застосування розробок і приводяться основні технічні характеристики деяких сенсорів.

Ключеві слова: акустоелектронні явища, поверхнево акустичні хвилі, сенсор, плівкові структури, адсорбція

Introduction

Sensors are basic elements of informational-measuring systems in any branch of science, engineering and production and they determine their metrological, operational and economic characteristics. It has predetermined intensive works development on perfection of sensors constructed on the basis of traditional principles and creation of essentially new microelectronic sensors using a new functional materials and structurally technological solutions integrated with microprocessor engineering. The evidence to that is the capital expenditure investments prompt growth for these works and volume of sales increase in the world sensorics and measuring systems market for the latest years.

In such developed countries as USA, Great Britain, Japan, Germany, for example, these works are carried on not only by the largest firms such as Honeywell, Motorola, Foxboro/ICT, Transamerica Inc., Sensor (USA), Simens, Wika (Germany), Druck (Great Britain), Kistler Instrumentation (Switzerland), Hitachi Ltd, Shibaura Electrics, Kyoto Ceramic, Riken Keiki (Japan), Onera, Jumo Regulation (France) etc., but also within the frameworks of state programs.

Such an intensive development of works on sensorics has induced USA, Japan and countries of Western Europe to create in 1981 the International Coordination Committee on Sensors and Actuators. In the Western Europe the community of the manufacturers of sensors (Arbeits-gemeinschaft Messwertaufnehmer, AMA) — Germany, Commision Industrie — Administration pour la Mesure, C.I.A.M.E. — France, and also Eurosensor, combining efforts of many countries is created. The international structure IEEE Sensors was formed. Information exchange on sensorics is realized through organizing international conferences and publication of journals.

The principal research directions were determined:

- sensors' metrological characteristics improvement;
- sensors' intellectualization problem solution.

The analysis shows, that in spite of available opportunities for sensors based on traditional principles and materials improvement, e.g. on semiconductors, the problem cardinal solution — is the creation of new generation sensor — intellectual sensors. It lays on the ways of using their new construction principles and new functional materials. One of the most perspective ways of a sensorics' problem solution is the use of acoustoelectronic phenomena which are realized especially at surface acoustic waves (SAW) propagation. Sensors of such type have metrological characteristics owing to their frequency type output signal and to functional materials usage. They are distinguished by their speed response and by their compatibility with microprocessor technique which ensures their intellectualization and "on — line "operation regime. It is necessary to note the opportunities of variety on functional purpose of acoustoelectronics sensors at a high degree of unification on the constructive — technological solutions. Their opportunities and advantages can be easily integrated with advantages of the other directions of functional microelectronics — molecular (Langmuir — Blodgett method), optoelectronics, acoustooptics etc. It is important also, that for manufacturing acoustoelectronics sensors on SAW, having planar structure, the well fulfilled technology of manufacturing of semiconductor devices and integrated circuits (IC) can be used. The application of group technology provides high repeatability the sensor characteristics and their low cost.

Acoustoelectronic sensors construction principles

It is necessary to notice, that on metrological sensor characteristics the technical requirements now have come nearer to limiting values. For example, for pressure sensors being most claimed on market, the range of liquids and gases measured pressures is limited by physical conditions of their existence and makes from 10^{10} up to 10^{10} Pa. And the range medium sensor measured temperatures spread from cryogenic up to values in liquid-metal circuit nuclearenergetic installations. The requirements on measurement accuracy depending on measured pressure are various and make from 0,05 % up to 5,0 % for the range of 10^{-4} — 10^6 Pa and 1 — 10 % in the field of vacuum systems and high pressure. Thus in many cases the increased requirements for the operational characteristics — radiation resistance, fire- and explosion safety, extended range of working temperatures, long-term characteristics stability, reliability are presented.

The principle of acoustoelectronic sensor action made on SAW is based on thermodynamic interrelation of electrical, magnetic, thermal and other parameters of SAW propagation in medium and opportunity of medium physical properties monitoring and, hence, SAW characteristics by means of the external influences of various physical and chemical nature application: thermal, electrical, magnetic fields and mechanical forces.

The sensitivity SAW — structure to influence of one or the other type is determined also by parameters SAW Euro medium, properties of contacting medium, SAW propagation direction in a crystal and features of a design. In SAW-elements tenso, — termo, — electroelastic interactions are used more often. A measure sensitivity interaction is the steepness sensitivity dependence of electro-physical medium properties and SAW propagation on size of the appropriate applied physical fields.

The classical structure acoustoelectronics sensor based on SAW does not differ from elements based on SAW of radioelectronic or radio engineering purpose, that also is the positive moment. It is a substrate — soundconductor made of piezoelectric material with putted on a working surface by one (resonator structure) or two (delay line — DL), located on some distance from each other interdigital converters (IDC).

In the widest class of sensor based on SAW — mechanical substitutes — for reception basic informative parameters tenselastic interactions are used. The significant amount of works is devoted to researches of tenseffect — the change of the SAW characteristics owing to mechanical deformations soundconductor [1-7]. The common expression for SAW velocity relative change V , received at the interactions analysis, within the limits of used assumptions is fair at external influences of a various physical nature and, hence, is applicable at consideration of various physical quantity sensor. The consideration of this effect is important too because

of in the majority of converters of other physical substitutes as the basic or parasitic effects also act tenselastical interactions.

The SAW converters, developed to the present time, on the action principle can be divided into three basic groups: with the use running SAW ; on the basis SAW standing; with addition of several SAW. A basic converters element with running SAW is the acoustic path such as delay line on SAW. The influence of external mechanical influences at soundconductor deformation results in the propagation running SAW characteristics change, in particular, of its phase speed V , and also to distance change l centre to centre IDC, that entails change a phase attack φ and SAW temporary delay τ at its propagation from IDC input to output .

The converter with standing SAW represents the acoustic resonator, in which standing SAW is raised. Such devices often name as converters with the resonator on SAW. The external influences cause change of SAW speed V and (at soundconductor deformation) geometrical sizes of the resonator that results in change of its resonant frequency.

The principle the converter with addition SAW action is based on interaction (interference) of several (usually two) SAW on a soundconductor surface, owing to what them often name as interference converters. The output signal of such converters is a consequence of change of a phase or amplitude (or simultaneous change of a phase and amplitude) one of interaction running SAW under influence of external influences, for example, soundconductor deformation. The complexity interference converter output signal elimination and processing complicates in the near future its use as mass, therefore basic attention is given to the first two types of converters.

Irrespective of a soundconductor material the phase attack magnitude φ at SAW propagation with phase speed V and frequency f between two soundconductor points, located on distance l , is defined as [8]:

$$\varphi = 2\pi f \tau \quad (1)$$

where $\tau = \frac{l}{V}$ — SAW temporary delay.

The deformation of a substrate as a result of influence on it of mechanical forces owing to tenselastical interaction results in change of SAW propagation speed ΔV and simultaneously — distances Δl between considered points. The total relative change of SAW phase attack at action of mechanical forces is defined by the ratio [9]:

$$\frac{\Delta \varphi}{\varphi} \sim \frac{\Delta l}{l} + \frac{\Delta V}{V} \quad (2)$$

where S — deformation in a direction of SAW propagation .

In mathematical model for tenselastical interactions size account [9] change of speed at SAW propagation in deformed media connects with change of modules of elasticity at action of deformation and density of the deformed substance, SAW propagation in media with mechanical pressure according to the modified movement equations, and also is caused by effects of thickness film change at deformation action for SAW-converters on the basis of layered structures.

The external influences of a various physical nature result in speed change ΔV of SAW propagation and also the length Δl of its trajectory. The control of external influences size, for example tenselastical interactions, can be carried out, as follows from the equations (1) and (2), just on time of a delay or SAW phase attack or by transformation of these quantities to some other.

In the most part of the mentioned above works the application of monocrystals as sensor soundconductor, for example piezoquartz SiO_2 of various sections was investigated. However such approach is connected with restriction of achievable values of the basic parameters of a sensor. It is connected first of all with monocrystal properties anisotropy shown in the fact that such soundconductor deformations do not give a pure mode of elastic fluctuations, in this case Rayleigh SAW. It complicates, in particular, task solution of definition of a useful signal appropriate physical quantities measured. Besides owing to electromechanical bond factor small values k_p the sensor high sensitivity and dynamic range values is not provided. In this connection we investigated tenseffect in converters on SAW base with piezoceramic soundconductor.

Piezoceramic materials have the best parameters compared with monocrystals on electromechanical bond factor k_p and mechanical quality Q_m . For example, piezoceramic of PCT system has value k_p up to 0,5, and the quality of the best marks achieves 1500. And k of piezoquartz depending on crystallographic section makes about 0,08 — 0,12. In polycrystalline materials there are no losses connected with a deviation of an acoustic beam and diffraction.

We developed and investigated the pressure sensor with tensensitive converter based on SAW as consol fixed piezoceramic (PC) plate.

Piezoceramic plate 20x7 mm size as consol attached in a wall of the sensor case, and the opposite edge was exposed to loading transmitted through a rod from a pressure source (fig. 1).

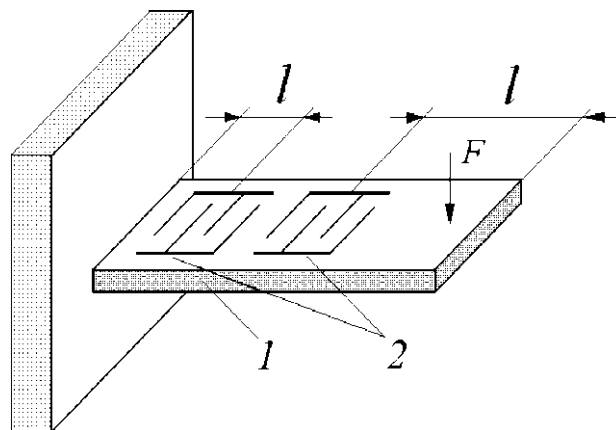

Fig.1. Block diagram of tensensitive converter on SAW: 1 — ceramic plates; 2 — IDC

The plate thickness was determined by requirements of sensitivity, dynamic range and mechanical durability. In our case the plate thickness was 1 mm. On a working surface two IDC, which as distinct from known designs of converters of the same purpose formed A FC of the narrow-band filter with the central frequency $f = 10$ MHz. The output IDC was resembling down with a step 3, where X — is the length of a wave corresponding f Such IDC design has a number of advantages in comparison with analogues — are provided achievement of optimum value of IDC impedance and sufficient selectivity of a useful signal at high element based on SAW as a whole manufacturability. The filter based on SAW generated thus was used in the measuring circuit as a set of frequency element in a circuit of feedback of the broadband amplifier.

The working frequency of an element based on SAW was selected proceeding from conditions of efficiency of signal processing at use of the generating circuit in one mode condition and also simplification of the requirements on technology (accuracy) IDC manufacturing . Higher working frequencies require the appropriate reduction IDC electrodes width and distance between them, i.e. the increases the technological requirements level and at the same time result in increase element on SAW with piezoceramic

soundconductor brought in losses. The plate end was pasted in a rigid wall of the case epoxy glue with components providing suppression of parasitic acoustic signals. The dynamic range is determined by size of mechanical quality concrete piezoceramic having for the various marks value from 680 for PZT-2 of Murata firm (Japan) up to 4500 for ПКР-53 of Rostov -on-Don Institute of physics (Russia).

Tenseffect was estimated on change of the central frequency f_0 of the SAW- filter $\Delta f = f - f_0$ (f — running value of frequency) depending on loading size on the free consol edge of attached PC plate with IDC structure using generating circuit.

During experimental researches it was determined, that from the point of view of transformation efficiency and a ratio signal / noise improvement the optimum IDC arrangement from console attached place (fig. 2) is defined by expression:

$$X = WnX/4, \tag{3}$$

where l — distance from the IDC center up to a attached place; W — IDC aperture ; n — simple odd number; X — wave length on the frequency of acoustic synchronism.

On the same distance from a point of the loading application the second IDC should be settle down. It is explained to that the parasitic acoustic signals, being reflected from acoustic inhomogeneity including console attached places with a phase $X/4$ are mutually compensated. Besides forming narrowband A FC of an element on SAW it is necessary to use IDC designs, giving SAW front maximum flat on amplitude.

The design mechanical part provides an opportunity loading amount transformation on a sensitive element providing a plate deformation at optimum distance from a limit of its durability.

It is important to note also one more advantage of the given converter, namely, opportunity to operate its sensitivity by a simple way — by geometrical sizes change and form of the PC plate.

In a fig. 2 the diagram frequency change sensor output signal dependence on pressure is given.

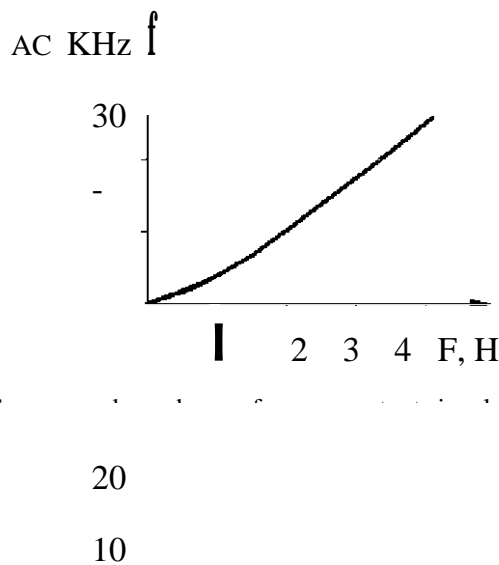

Fig. 2. Dependence of frequency change sensor output signal dependence on pressure

It is not difficult to see, that on a basis of tenseffect with tensensitive element on SAW use it is possible to construct not only pressure sensors, but also linear and angular moving, temperature and other physical quantities sensors, using in them trivial converters of the appropriate quantities in mechanical loading.

Considered above curve-kind deformations is most often used because of more simple interrelations between mechanical influence and output parameters of an electrical sensor. It at the given stage of researches simplifies examination of the physical mechanism and gives faster practical result. However it at all does not mean, that other kinds of deformations: the compression, stretching, spinning, shift and combined, also resulting to change of constant elasticity c_{ij} and denseness n of the material, owing to what the acoustic wave speed propagation varies, has no prospect.

The researches in this direction can expand the range sensors constructed on this principle achievable parameters values, and also the area of their application.

The other perspective principle physical quantities sensors construction which we offered is the use the angular dependence SAW phase speed phenomenon in monocrystal piezoelectric [10]. In this case SAW excitation and the detecting is carried out by noncontact method applied for the first time by A. G. Sokolinskiy [11] in a DL with adjustable time of a delay.

The noncontact converter (NCC) represents a pair IDC, putted by a thin-film method on dielectric substrate, for example, sintered quartz. The SAW excitation and reception during measurements is carried out by an alternating electrical field penetrating through a gap between IDC and a working surface of a investigated piezoelectric plate (fig. 3).

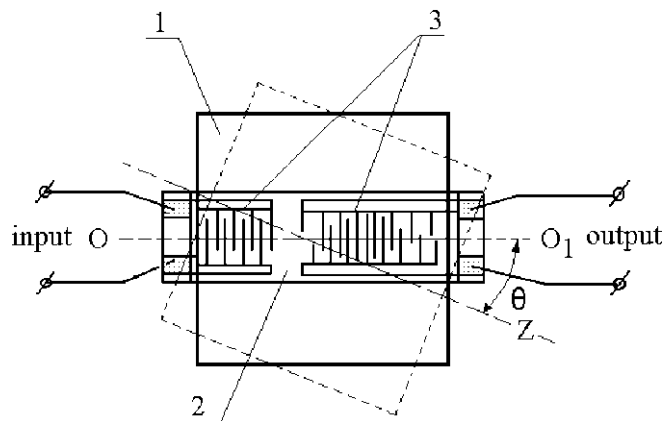

Fig. 3. The NCC scheme . 1 — piezoelectric soundconductor, 2 — dielectric plate with IDC, 3 — IDC

The V definition is based on interrelation V and excitation frequency that express by a ratio:

$$V = \lambda / \omega, \quad (4)$$

where λ — SAW length.

As for equidistant IDC $\lambda = 2t$, where t — IDC step (period of electrode sets), at $t = \text{const}$ the f_0 change can be connected only with V change and, hence, V value can be received by f_0 measurement and by its division by factor $K = 1 / \lambda$, i.e.:

$$V \approx f_0 K \quad (5)$$

As in anisotropic piezoelectric, in particular SiO_2 ST — and Y sections the essential angular dependence SAW phase speed (fig. 4) takes place, any one disordered orientation IDC system with a constant electrodes step in relation to crystallographic axis results in converter output signal frequency change.

The large linear diagram part for SiO_2 and dependence steepness stimulated development of idea this effect use for creation physical substitute sensors. In such sensor the mutual orientation IDC input

and output systems can change by various kinds of influence — angular and linear moving , pressure, temperature and, thus, can be created the sensor of the appropriate substitutes and purposes.

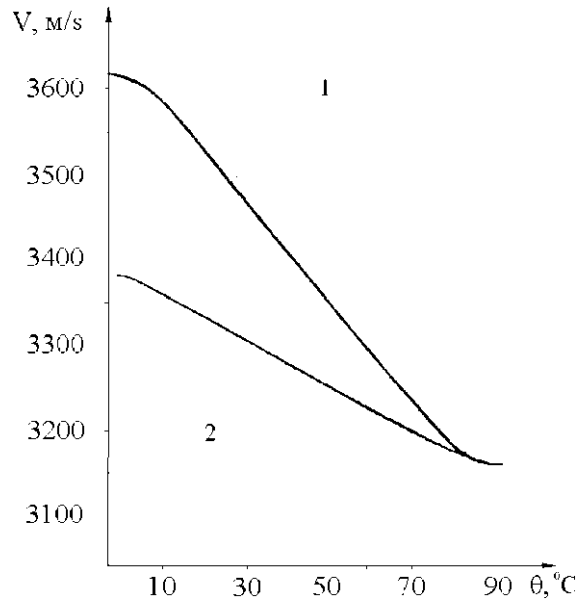

Fig. 4. Angular dependence SAW propagation phase speed in quartz. 1 — ST-section, 2 — Y-section.

The investigations of efficiency dependence of noncontact transformation on gap size between a IDC plane and piezoelectric working surface for task geometrically shown in fig. 5 were carried out.

1

The expression for transformation relative efficiency

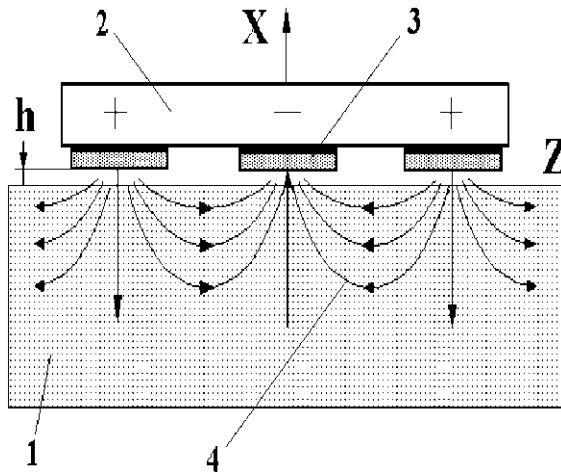

Fig. 5. Geometry SAW noncontact excitation task. piezoelectric half-space, 2 — dielectric plate, 3 — IDC electrodes, 4 — electromagnetic field lines of force.

dependence on normalized section size is received as:

$$\frac{E_{rel}}{E} = (1 - tgkh)(1 + stgkh), \tag{6}$$

where k — wave count; h — gap size; ϵ — relative piezomaterial dielectric constant.

This principle may be considered as basic for a new class physical substitutes sensors and directed acoustoelectronic apparatus creation.

On this principle the angle rotation, linear moving and pressure sensors are developed [12-16]. Such sensors can be used:

- in a complex of the automated equipment of various kinds of manufacture;
- in a robotics;
- in motor industry;
- as the separate device of measuring engineering and instrument making.

The rough development communication systems and data processing with Infra-Red (IR) radiation application raises urgency the sensor researches, directed on IR radiation sensors perfection. With reference to IR sensors it concerns first of all increase of such important parameters as sensitivity, selectivity on a spectral range, speed of response, and also opportunity sensor intellectualization by coupling them with microprocessor engineering and minimization mass and size parameters.

Is known, for example, a temperature sensor design [16], containing a piezoelectric plate and interdigital resonant structure (resonator on SAW). However it has low sensitivity heat sources to IR radiation too.

We developed IR sensor on the basis of layered structure the semiconductor — piezoelectric in which the effect of semiconductor selective photosensitivity and the speed SAW propagation change under influence of temperature on a piezoelectric soundconductor plate is used. The combination of optical and temperature properties of semi-conductor and piezoelectric materials in uniform structure has allowed to create a highly effective IR-sensor. In fig. 6 the design of a sensor is schematically shown.

The sensor contains a piezoelectric plate made of a transparent for IR-radiation material in the wave lengths region of $\lambda = 3,0 \text{ н } 5,0$ microns and having a large frequency temperature factor, on which the interdigital resonant structure is located, and on a plate surface in the region of an interdigital resonant structure and acoustic channel arrangement the layer of a semi-conductor material sensitive to IR-radiation in wave lengths range $\lambda = 3,0 \text{ н } 5,0$ microns is putted.

The sensor piezoelectric plate 2 (fig. 6) is made of lithium niobate LiNbO_3 , turned under the angle 128° YX-section of material transparent for IR-radiation in a range of wave lengths of $\lambda = 0,4 \text{ н } 5,0$ microns and having a large frequency temperature factor of (FTF) equal $69 \times 10^{-6} \text{ Hz/ } ^\circ\text{C}$, interdigital resonant structure 3 and thin layer of a photosensitive semiconductor material 1. As the last india antimonide (InSb) was used. Depending on resonant structure working frequency, thickness material sensitive in a wave lengths region $\lambda = 3,0 \text{ н } 5,0$ microns to IR- radiation putted on a region of interdigital resonant structure and the acoustic channel can be various.

The sensor works as follows. At electrical signal injection at IDC 2 (fig. 7) in soundconductor piezoelectric the SAW are excited and are extended in both site of IDC, are reflected from reflectors 3, forming a resonant cavity.

At the certain ratio the resonant cavity sizes and working frequency determined by distance between IDC electrodes and SAW speed propagation in a piezoelectric soundconductor material and also owing to piezoeffect reversibility the electrical resonance takes place. The sensor IDC outputs 2 are connected with the amplifier feedback circuit 5, forming the generator on SAW, which output is connected through the filter of the lower frequencies 6 with the registrar (fig. 7).

Temperature stability SAW-resonator characteristics are determined mainly by piezomaterial temperature stability.

In the absence IR radiation the resonator has resonant frequency given by its elements constructive sizes and the medium temperature. At IR radiations source switching the InSb layer, putted on sound-conductor with interdigital structure, absorbs IR beams and warms up it changing thus propagation

SAW speed amount. To change SAW speed it is enough to warm up only superficial soundconductor layer with thickness to approximately equal of an acoustic wave length λ_0 , in which the basic part SAW energy is

concentrated. Thus sensor high sensitivity to temperature and small inertia especially necessary in case of parameters pulse IR-sources measurement is provided.

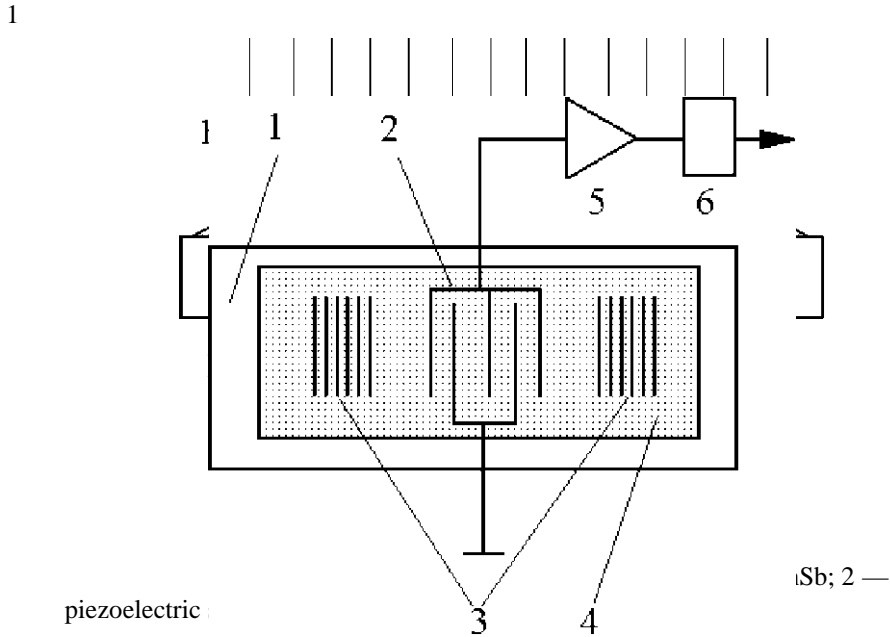

Fig. 7. Acoustoelectronic IR- radiation sensor. 1 — piezoelectric soundconductor (LiNbO3); 2,3 — SAW resonator structure; 4 — InSb film; 5 — amplifier; 6 — LFF.

Strictly speaking, in such structure the double temperature influence on SAW propagation conditions — linear soundconducting material widening and SAW speed change by the way an acoustic impedance change take place. In [16] the total these effects influence is analyzed and the following expression for frequency change is received

$$\frac{V_1}{V_0} = 1 + \frac{(Y_m - Y_{ou})AT}{V_0} \quad (7)$$

where V_0 — the initial SAW propagation speed;

V_1 — SAW speed changed wing to temperature influence;

Y_{in}, Y_{out} — temperature factors before and after temperature influence accordingly; AT — temperature increase from its value correspond to V_0 .

However for one input SAW resonator, that takes place in our case, the soundconductor widening can be neglected.

The SAW speed change, thus, results in SAW resonator resonant frequency appropriate changing, that is the sensor output signal depending on IR radiation intensity. THE SAW resonator is included in the generator circuit, as it is described above. Such circuit for processing signals with variable frequency has a number of known advantages.

The sensor sensitivity comes to 5142 Hz/ °C, the top limit of temperature measurement is determined mainly by the sound conductor material temperature characteristics, that's why it is high enough, because of the piezoelectric plate LiNbO3 Curie point is equal ~1200 °C.

The sensor is made by methods of group thin-film technology, that causes high repeatability of its parameters, manufacturability and low cost price.

The sensor is used with success in the measuring purposes, in particular, in the equipment with KGT type lamps, having radiation spectrum in a range $\lambda = 3,0, 4,0$ microns.

The stated above principle IR acoustoelectronics sensor construction is effective enough also because it gives the possibility this class sensor expansion by a layered structures components combination. Selecting semiconductor and piezoelectric materials with the appropriate electrophysical parameters and photosensitivity properties it is possible to create sensors with the given on a spectral range characteristics. It is possible also to create structure from several layers of photosensitive semiconductors with different width of the forbidden zone. Thus, however, it is necessary to mean restrictions of the acoustic plan not to create a condition useful SAW signal strong suppression or Rayleigh SAW transformation in to the other waves types having, for example, dispersion.

The acoustoelectronic sensors feature and major advantage is that on the basis of the base structure — IDC on piezoelectric soundconductor not only physical substrates sensors, but also gas sensors can be created. Two approaches can be realized here at least.

In the first of them the adsorptive sensitivity to gases of the soundconductor piezoelectric — converter itself is used, made for example of some piezoceramic marks.

In the second case on a working soundconductor surface on the way of SAW propagation the layer adsorptive sensitive material is putted [17-20].

The physico-chemical processes layered adsorptive structures with gas medium interactions influence the SAW propagation conditions, that is adequately reflected in the SAW-element output signal parameters.

Such principle gas sensors construction is rather productive, especially in a combination to methods of molecular electronics. The last allows thanks to receptor properties of film structures made by Lengmuir-Blodgett method to solve a problem sensor sensitivity and selectivity and the element on SAW with frequency kind output signal is rather easy to intellectualize sensor by coupling it with the microprocessor.

Externally rather simple principle such type gas sensor construction has attracted attention of many developers. However it has some "reeves " because of which the experimental results of the different authors not always coordinate among themselves and theoretical accounts.

By many authors it is accepted, that the phase SAW Rayleigh propagation speed relative change, that is equivalent to frequency element on SAW relative change, which is caused by a film thickness h , agrees [21] as a first approximation is defined by expression:

$$\frac{\Delta V}{V} - \frac{cokhp}{4Q} \left\{ V_{it}^2 \left[4 \left(1 - \frac{V_{it}}{V_{li}} \right) U_1^2 + U_2^2 \right] - V^2 [U_1^2 + U_2^2 - U_3^2] \right\} \quad (8)$$

where V — SAW speed;

Q — energy flow of not disturbed wave in the direction of the wave vector per unit of width, perpendicular to sagittal area;

V_t — SAW shift speed in a film material of;

V_{it} — SAW longitudinal speed in film material;

U_1, U_2, U_3 — displacement components on a free surface for not disturbed wave;

ρ_z — film material density;

k — wave number.

The analysis (8) shows, that $\Delta V/V$ caused by a film, has a sign which depends mainly on a ratio of wave shift speed in the film material to the speed of the not disturbed Rayleigh wave in soundconductor. It not to the full corresponds to a physical picture having a place at SAW passage in layered structure. Generally SAW-response parameters depend on:

- sorption film acoustic properties and electrophysical parameters, which can change in adsorption-desorption process;
- material soundconductor and film acoustic characteristics ratio;

- frequency working range;
- films geometrical sizes;
- medium pressure;
- film temperatures.

The adsorption process can be accompanied by significant thermal effect, as, for example, at adsorption of ammonia on zeolite, that itself can cause SAW speed change owing to sound conductor heat.

The only acoustic effects can influence the results, for example, connected with geometrical sizes and wave length ratio, the film and soundconductor acoustic characteristics of which may vary at adsorption. It can result in that the parameters of the SAW-response will change not from, for example, sorption film bulk or elastic constants change, but owing to one waves type in another transformation effect, in particular Rayleigh SAW in Lamb's waves, which have another properties. The Lamb's waves, having a place at $kh \sim 1$, differ, for example, by dispersion, that's why change of chosen for SAW -response frequency or phase output parameter measurements will appear not adequate to Rayleigh SAW frequency change, that can result in not absolutely correct interpretation of the received results.

The situation is possible, when the wave speed shift in a film becomes greater the speed in sound-conductor and then the phase speed is increased and when it achieve the amount of volumetric shift speed in soundconductor arises its deepening in soundconductor. The consequence — the essential decrease the adsorption-desorption on a soundconductor surface processes influence efficiency on of the SAW response parameters .

In the other cases owing to interaction of a film with chemical components of controllable medium the SAW speed in it decreases so, that the situation of a "slow" wave on "fast" soundconductor creates and then the acoustic field is focused in a film. Channaled thus wave is slow than Rayleigh wave on a free soundconductor surface, and it is the less, the more the ratio film width L to its thickness h and at $L/h = 15.6$ [22] it becomes essential dispersion. Thus V will depends on f and to eliminate f or V dependence on change during measurements the gas concentration controllable component becomes problematic.

Thus for evaluation of the results of sorption film on a SAW -lement soundconductor surface interaction with gas components it is necessary to ensure stable existence SAW of the certain type with known properties Rayleigh SAW best of all during all measurement cycle.

The experimental researches we carried out on classical structure of an element based on resonator type SAW with soundconductors made of piezoquarts and piezoceramic [23]. Sorption films were putted by a Langmuir-Blodgett method. As a material of a sorption film the new functional material Germanium complex compound (GCC) with oxyethylidendiphosphon acid was used [24]. In fig. 8 the adsorption-desorption kinetics in GCC films at ammonia and benzol vapours influence is shown. It is necessary to notice, that the given data are received without heating at desorption stage, that is essentially important at creation intellectualized sensors.

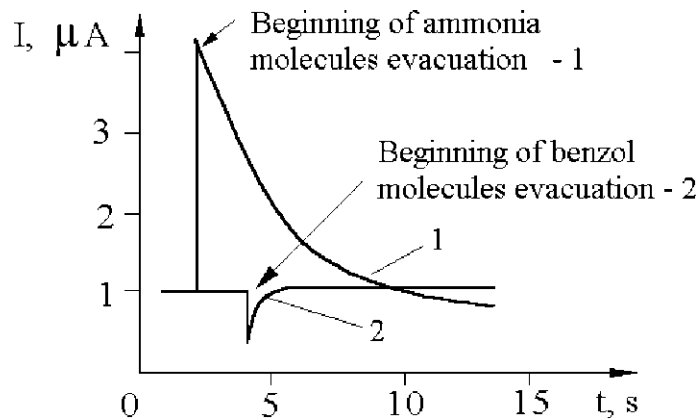

Fig. 8. Kinetics of the adsorption-desorption process in GCC films. 1 — in ammonia vapour (10 %); 2 — in benzol vapour (50 %).

We investigated also the sensor selectivity increase method by the layered structures such as "sandwich" [25] formation, in which one layer plays a role of a molecular sieve, and another shows a high degree of solubility to certain gas component, than the double selectivity is reached.

Conclusion

The above mentioned review of acoustoelectron phenomena and the author results of researches, on the basis of which the sensors can be created, reflects a part of most investigated and most perspective, in the author opinion of them. This developing class of sensors in a sufficient measure corresponds to the modern demands showed to the new generation sensors — the essential increase of metrological characteristics parameters and intellectualization with work in real time scale.

Literature

1. Milkyavichene E.A., Sereiko A.P. The SAW converter on a basis of tensensitive CdS layer / The Letters in JTPh. — 1985, -v.11. — № 1. — P.18-21.
2. Koleshko V.M., Meshkov Yu.V. Microelectronic information converters on surfase acoustic waves //Foreign Electronics. — 1985. — № 9. — P.3-116.
3. Rechetskii V.I. Acoustoelectronic radiocomponents. Circuit, topology, constructions. — M.: Radio and Communication. — 1987. — 192p.
4. Gulyaev Yu.V., Koleshko V.M., Meshkov Yu.V. Tenseffect in structures on surface acoustic waves with soundconductor made of monocrystal quartz // Radio Engineering and Electronics. — 1988. — V.33, №11. — P 2448-2451.
5. Kittinger E., Tichy J. Electroelastic effect of crystal rods expressed by fundamental material constants // J. Acoust. Soc. Amer. — 1988. — Vol. 83. — № 2. — P.647-651.
6. Tilmann Z.U. Strain sensor with commercial SAWR // Sensor and Actuators. — 1989. — Vol.17. — № 1-2. — P.235-239.
7. Lepikh Ya. I. Strain effect in surface acoustic wave with a piezoelectric acoustic line and sensors based on this effect // Semicond. Phus. Quant. Electron. Optoelectron. — 2000. — V.3. — № 1. — P.91-93.
8. Integral piezoelectric signal filtration and processing apparatus. Edited by Akpambetov V.B. — Radio and Communication. 1985. — 123p.
9. Rider T.N., Kallen D.I. Pressure and temperatures sensors using SAW // IEEE. — 1976. — V.64, №2. — P.226-228.
10. Lepikh Ya.I. Invastigation of angular dependence of SAW speed in quartz of various crystallo-graphic sections// In book.: Acoustoelectrical and photoacoustic methods substitute research. — K. — 1989. — P.102-104.
11. Sokolinskii A.G. The alternative ultrasonic delay line on the base of Rayleigh waves //Radioelec-tronics questions. Ser. Common technical. — 1971. — № .1. — P.86-94.
12. Lepikh Ya. I. The mechanical substitutes sensors based on surface acoustic waves // 35 intern. wissenschaftliches kolloqvium techn. hoch schule / Cmenau. DDR-1990. — Vortragsreihe. B9. — P.80-82.
13. Lepikh Ya.I. The sensor with an element on SAW for film thickness measurement// Experiment Devices and engineering. — 1996- №6. — P.145.
14. Lepikh Ya.I. Acoustoelectron sensors for equipment and technological processes which coupling with computer//Measuring computing technique in technological proseses. — 2001. — №.8-P.472-475.
15. Lepikh Ya.I., Chernyak N.G. Features pressure sensors on SAW development for AES // Technology and designing in electronic apparatus. — 2002. — №.1.—P.17-21.

16. Meyer P.S., Shulz M.B. Temperature effects in reflective Surface acoustic wave delay lines// Tllectron.Lett. — 1993. — № 9. — P.523.
17. Anisimkin V. I., Koteljanskii I.M., Verona E., Penza M. Proceedings internat. Symp. Acoustoelectronics, Frequency control, signal generation 17-19 Sept. 1996. Moscow, 123-127 (1996).
18. Horrillo M.C., Fontecha J.L., Sayago J. and the other. Detection of hydrocarbons using SAW and resistive sensors // Book of Abstracts. "EurosensorXVI", Sept. 15-18, 2002, Prague, Czech Republic.
19. Korenman Ya.I., KalachA.V.,Rusanova T.Yu., Shtykov S.N. Application of piezosensors on the basis LB arakhin acid films for nitroalkane detecting in air // Sensor, № 2, June 2002, p. 14.
20. Kryshthal' R.G., Kundin A.P., Medved' A.V., Shemet V.V. The sorption type gas sensor on surface acoustic waves sensitive to gases thermal properties //Letters into JThPh, 2002, V. 28, №. 2, P. 25.
21. Auld B.A. Acoustic Fields and Waves in Solids. V.2 (New York: Wiley, 1973).
22. Slobodnik E. IEEE. 64, №5, 10-26 (1976).
23. Lepikh Ya.I. Investigation of gas sensor elements on surface acoustic waves with film structures properties//Scientific bulletin Chernovtsy F. Fedkonich State University — 2000. — №86. — P. 96-100.
24. Lepikh Ya.I., Smyntyna V.A., Khomenko M.V. and the other. Functional properties of materials on the base of Germanium Coordination Compounds// In the book: Articles of international scient. — techn. conference "Functional materials". Yalta. — 2003. — P.41.
25. Lepikh Ya. I., Smyntuna V.A., Pronichkin V.D. Workshop " Sensors springtim in Odessa ". 2930. May 1998. Odessa. — Ukraine, 48 (1998).